

## ARC-1214-4I/1224-8I

(4/8-Port PCIe 2.0 Internal SAS RAID Controllers)

ARC-12x4 internal PCIe 2.0 host RAID controllers are a cost-effective solutions for connecting up to 4/8 6Gb/s SAS peripheral devices. The RAID controllers are based on the same RAID kernel of field-proven internal/external RAID controller and same device driver architecture with widely used 3Gb/s and 6Gb/s SAS RAID controller. Applications that benefit most features from these controllers include NAS, server RAID solutions, web servers, near-line backup, security systems and streaming applications. ARC-1214-4I/1224-8I support directly attached 4/8 internal 6Gb/s SAS ports via 1/2 SFF-8087 connector.

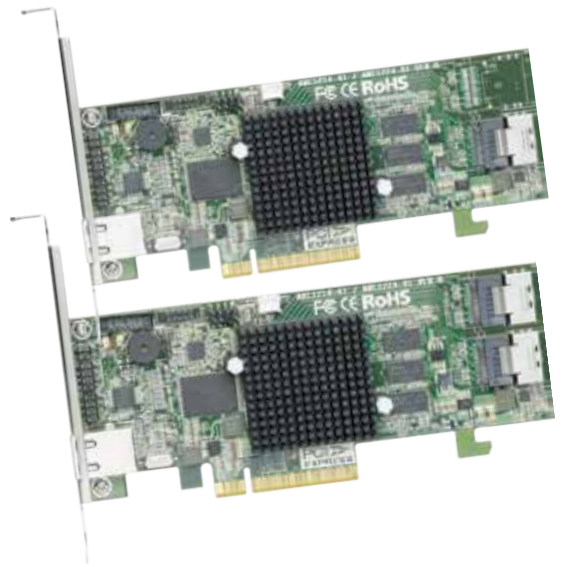

### Highlights

- PCIe 2.0 x8 lane host interface
- Greater than 2TB capacity per disk drive support
- Support greater than 2TB per volume set and battery backup module (BBM)
- Enclosure management (Serial bus and SGPIO) ready
- Support intelligent power management to save energy and extend service life
- Support NTP protocol synchronize RAID controller clock over the on board Ethernet port
- Broad operating support including Windows, Linux (open source), FreeBSD(open source), Soaris(open source), Mac and VMware

### Unparalleled Performance

Embedded with ARM-based storage I/O processor makes those products a pure hardware RAID controller and raise the standard to higher performance levels with several enhancements including 6Gb/s SAS ports, on-board 1GB SDRAM memory and high performance PCIe 2.0 x8 lane host interface bus interconnection. The optional battery backup module provides power to the cache if it contains data not yet written to the drives when power is lost. With several port configuration options including 8 internal, and 4 internal, Areca 6Gb/s SAS RAID adapters deliver the ideal price/performance and connectivity solution for entry-level server platforms, workstation.

### Unsurpassed Data Availability

As storage capacities continue to rapidly increase, users need greater level of disk drive fault tolerance, which can be implemented without doubling the investment in disk drives. The RAID 6 can offer fault tolerance greater than RAID 1 or RAID 5 but only consumes the capacity of 2 disk drives for distributed parity data. ARC-12x4 series SAS RAID controllers with extreme performance RAID 6 engine installed provide the highest RAID 6 feature to meet this requirement. The controller can concurrently compute two parity blocks and get very similar RAID 5 performance.

ARC-12x4 series 6Gb/s SAS RAID controllers can also provide RAID levels 0, 1, 1E, 3, 5, 6, 10, 30, 50, 60, Single Disk or JBOD for maximum configuration flexibility. Its high data availability and protection derives from the following capabilities: Online RAID Capacity Expansion, Array Roaming, Online RAID Level / Stripe Size Migration, Global Online Spare, Automatic Drive Failure Detection, Automatic Failed Drive

Rebuilding, Disk Hot-Swap, Online Background Rebuilding, Instant Availability/Background Initialization, Auto Reassign Sector, Redundant Flash Image and Battery Backup Module. Greater than Two TB Support allows for very large volume set application in 64-bit environment such as data-mining and managing large database.

### Maximum Interoperability

ARC-12x4 series 6Gb/s SAS RAID adapters support broad operating system including Windows 8/2012/2008/Vista/2003/XP, Linux (Open Source), FreeBSD (Open Source), VMware, Solaris (Open Source), Mac and more, along with key system monitoring features such as enclosure management (SES2, SMP & SGPIO) and SNMP function. Our products and technology are based on extensive testing and validation process; same as Areca SAS RAID adapter field-proven compatibility with operating systems, motherboards, applications and device drives.

### Easy RAID Management

The controllers contain an embedded McBIOS RAID manager that can access via hot key at M/B BIOS boot-up screen. This pre-boot McBIOS RAID manager can use to simplify the setup and management of RAID controller. The controller firmware also contains a browser-based McRAID storage manager which can be accessed through the Ethernet port or ArcHttp proxy server in Windows, Linux, FreeBSD and more environments. The McRAID storage manager allows local and remote to create and modify RAID set, volume set, and monitor RAID status from standard web browser. The Single Admin Portal (SAP) monitor utility can support one application to scan multiple RAID units in the network.

## Controller Architecture

- ARM\_based 933MHz storage I/O processor
- 1GB on-board DDR3-933 SDRAM with ECC protection
- PCIe 2.0 x8 lanes host interface
- Support up to 4/8 internal 6Gb/s SAS physical links
- ARC-1214-4I supports up to 4 x 6Gb/s SAS/SATA HDDs
- ARC-1224-8I supports up to 8 x 6Gb/s SAS/SATA HDDs
- Multi-adapter support for large storage requirements
- BIOS boot support for greater fault tolerance
- BIOS PnP (plug and play) and BBS (BIOS boot specification) support
- Support EFI BIOS for Mac Pro
- NVRAM for RAID event & transaction log
- Redundant flash image for controller availability
- Battery Backup Module (BBM) ready (Optional)
- RoHS compliant

## RAID Features

- RAID level 0, 1, 10(1E), 3, 5, 6, 30, 50, 60, Single Disk or JBOD
- Multi-level RAID 0 and RAID 10 (R00 and R100)
- Support up to 1MB stripe size
- Multiple RAID selection
- Online array roaming
- Online RAID level/stripe size migration
- Online capacity expansion and RAID level migration simultaneously
- Online volume set growth
- Instant availability and background initialization
- Support global and dedicated hot spare
- Automatic drive insertion/removal detection and rebuilding
- Greater than 2TB capacity per disk drive support
- Greater than 2TB per volume set (64-bit LBA support)
- Support intelligent power management to save energy and extend service life
- Multiple pairs SSD/HDD disk clone function
- SSD automatic monitor clone (AMC) support

### • Electrical

Power Requirements:	On 3.3 V: 4.95W
	On+12V: 6.22W

## Monitors/Notification

- System status indication through global HDD activity/fault connector, individual fault connector, LCD/serial bus connector and alarm buzzer
- SMTP support for email notification
- SNMP support for remote manager
- Enclosure management (Serial bus and SGPIO) ready

## RAID Management

- Field-upgradeable firmware in flash ROM

### In-Band Manager

- Hot key "boot-up" McBIOS RAID manager via M/B BIOS
- Web browser-based McRAID storage manager via ArcHttp proxy server for all operating systems
- Support Command Line Interface (CLI)
- API library for customer to write monitor utility
- Single Admin Portal (SAP) monitor utility

### Out-of-Band Manager

- Firmware-embedded web browser-based McRAID storage manager, SMTP manager, SNMP agent and Telnet function via Ethernet port
- API library for customer to write monitor utility
- Support push button and LCD display panel (Optional)



## Operating System

- Windows 10/8/Server2012/7/2008/Vista/Server 2003/XP
- Linux
- FreeBSD
- VMware
- Solaris 10/11 x86/x86\_64
- Mac OS 10.5.x/10.6.x/10.7.x/10.8.x/10.9.x

For more information & latest supported OS listing visit [www.areca.com.tw](http://www.areca.com.tw)

### • Environment

Operating	Temperature: +5°C to +60°C Humidity: 15-80%, non-condensing
Storage Temperature	Temperature: -40°C to 70°C Humidity: 5-90%, non-condensing

Model Name	ARC-1214-4I	ARC-1224-8I
I/O Processor	ARM_based 933MHz storage I/O processor	
Host Bus Type	PCIe 2.0 x8 Lanes	
Drive Connector	1xSFF-8087	2xSFF-8087
Drive Support	Up to 4 x 6Gb/s SAS/SATA HDDs/SSD	Up to 8 x 6Gb/s SAS/SATA HDDs/SSD
RAID Level	0, 1, 1E, 3, 5, 6, 10, Single Disk, and JBOD	0, 1, 1E, 3, 5, 6, 10, 30, 50, 60, Single Disk, and JBOD
On-Board Cache	1GB on-board DDR3-933 SDRAM with ECC protection	
Management Port	In-Band: PCIe / Out-of-Band: LCD and LAN Port	
Enclosure Ready	Individual Activity/Faulty Header, Serial Bus and SGPIO	
Form Factor (H x L)	62 x 168 mm	
Products View		



Areca is a registered trademark of Areca Technology Corporation. Other brand names and product names are trademark or registered trademarks of their respective companies. This specification may be changed at any time without prior notice.



8F., No.22, Lane 35, Ji-Hu Rd., 114Taipei, Taiwan, R.O.C.  
TEL: 886-2-87974060 FAX: 886-2-87975970 <http://www.areca.com.tw>  
Technical Support: [support@areca.com.tw](mailto:support@areca.com.tw) Sales Information: [sales@areca.com.tw](mailto:sales@areca.com.tw)